

XT-FCC400 High-Speed Electric Oilfree Compressor for Fuel Cell Air Loop

Technical Specification

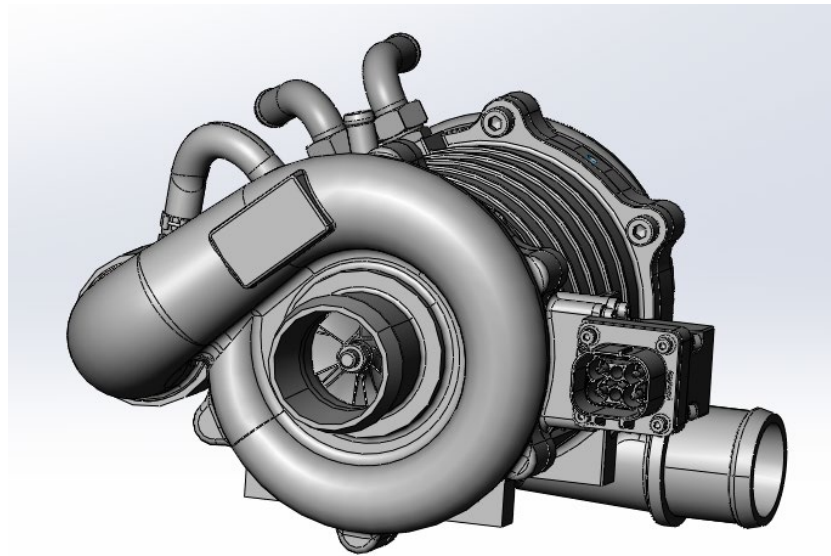

Xeca Turbo

File archive information					
Document Number		Approval Date		Effective Date	
Confidentiality level		Version			
Page		Number of pages in the main text		Appendix Page Count	
Establishment		Check		Examine	
Countersign					
Approve					
Change Description					
Related Files					

Contents

1. Product List.....	1
2. Performance Parameters	2
2.1 Air Compressor Parameters of FCC400	2
2.2 Critical Technical Parameters	3
3. Joint definition	6
3.1 Compressor host pin definition.....	6
3.2 Connector pin definition	7
4. Design verification tests.....	10
5. Product Installation.....	12
5.1 Product Fixation.....	12
5.2 Coolant Line Connection	13
5.3 Air compressor ground wire connection.....	13
5.4 Electrical Connections	14
5.5 Air Compressor Rotation Direction Confirmation	14
5.6 Air Duct Connection.....	15
5.7 Checklist	15
6. Operation and Shutdown	16
6.1 Operation	16
6.2 Shutdown	16
6.3 Troubleshooting.....	17





7. Warnings & Cautions.....	18
8. After-sales Service.....	1

XT-FCC400 High-Speed Electric Oilfree Compressor for Fuel Cell Air Loop Technical Specification

1. Product List

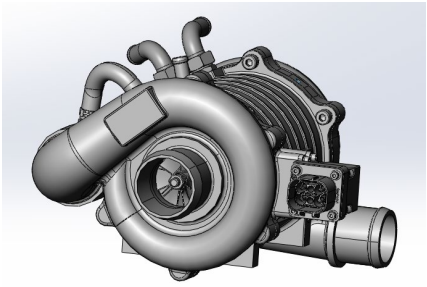
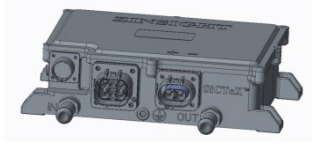
Table 1 Product details

Name	Model	Legend	Notes
Air compressor	XT-FCC400H Customised edition		
Controller	HS40-6D4T		
AC harness	UPMTB1015002		

2. Performance Parameters

2.1 Air Compressor Parameters of FCC400

Table 2 Air compressor parameters of FCC400

Name	Parameter	Unit	Notes
Maximum speed of air compressor	95000	r/min	
Minimum speed of air compressor	30000	r/min	
Working environment temperature	3.8~149	°F	
Air inlet temperature	3.8~113	°F	
Air inlet pressure	10.15~14.5	psi	
Storage temperature range	-6.2~185	°F	
Motor temperature sensor	PT1000		
Coolant type	Glycol mixed with water		
Coolant temperature	3.8-158	°F	Higher than inlet /ambient temperature 50~53.6°F
Air compressor coolant flow	1.3-2.2	UK gal/min	
Air compressor runner volume	0.056	UK gal	
Maximum pressure of cooling medium	36.26	psi	
Dry insulation	≥20	MΩ	
Wet insulation	≥20	MΩ	
Air inlet size of air compressor	Φ2.24	inch	
Air outlet size of air compressor	Φ2	inch	

2.2 Critical Technical Parameters

2.2.1 The key technical parameters of FCC400H with customised edition are shown in Table 3

Table 3 The key technical parameters of FCC400H with customised edition

2.3.1.1 Air compressor map curve of FCC400H with customised edition is shown in Figure 1

Name	Parameter	Unit	Notes
Max flow	180	g/s	Pressure ratio 2.43
Rated flow	170	g/s	Pressure ratio 2.47
Rated power	21	kW	sea level
Peak power	22	kW	
Maximum outlet temperature	320	°F	inlet temperature 77°F @ Pressure ratio 2.47
13.5Air compressor weight	<13.5	kg	
Rated heat dissipation of air compressor	1.1	kW	

Frame 001 | 15 Aug 2025 | XT-FCC400HDZ-map

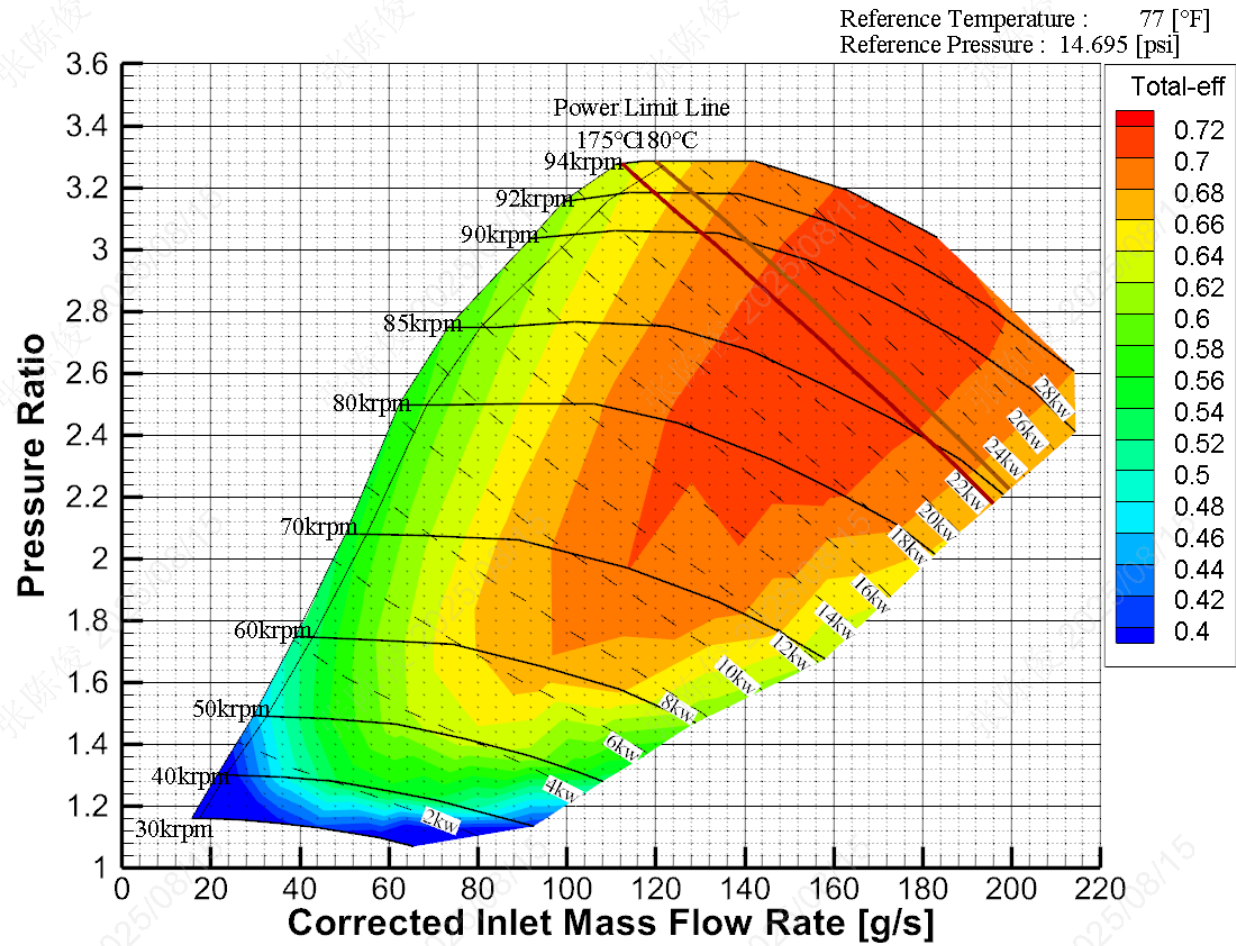

Figure 1 Air compressor map curve of FCC400H with customised edition

2.2.2 Flow Resistance Curve of Cooling fluid

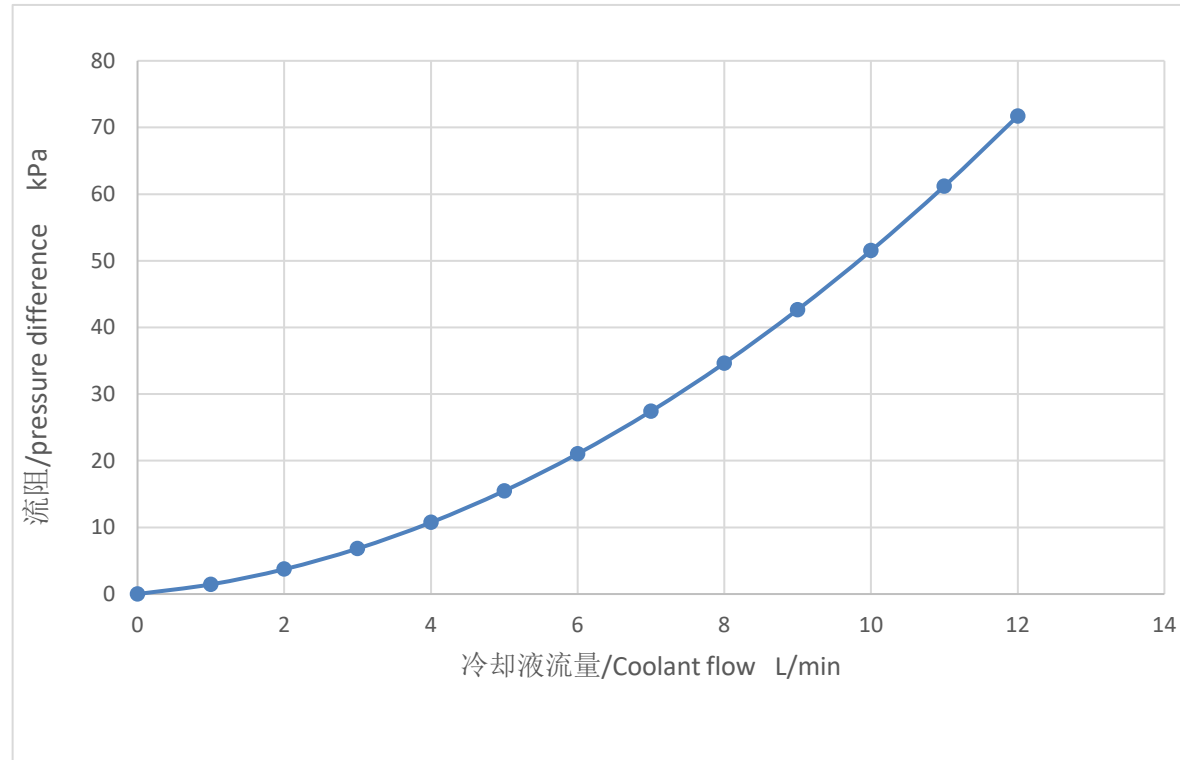
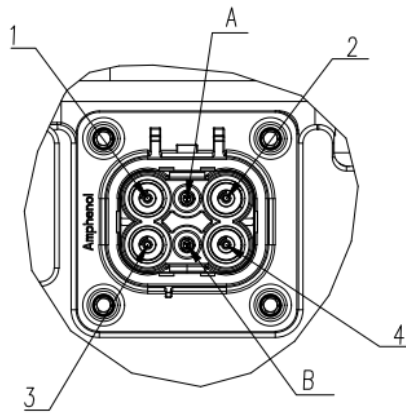

Figure 2 Air Compressor and Controller Flow Resistance Curve

3. Joint definition

3.1 Compressor host pin definition

Name	Joint socket-picture	Model	Factor	NO	Name	Signal Type
High voltage communication		C10-765871-4AP4 (subassembly)	Amphenol	1	U phase output	U
				2	V phase output	V
				3	W phase output	W
				4	Motor ground	PE
				A	Temperature feedback positive	PT1000+
				B	Temperature feedback negative	PT1000-

3.2 Connector pin definition

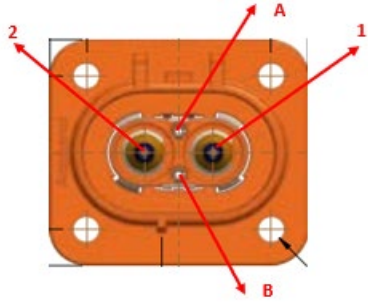
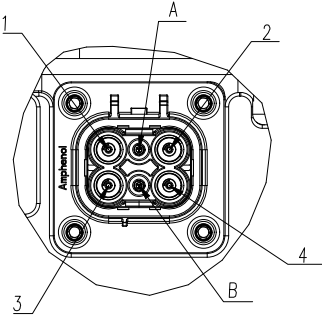
Name	Joint socket-picture	Model	Factor	NO	Name	Signal Type
High voltage communication		C10-766948-2AP4 (subassembly)	Amphenol	1	HVDC Negative	HVDC-
				2	HVDC Positive	HVDC+
				A	High-Voltage Interlock	HVLOCK
				B	High-Voltage Interlock	HVLOCK
High-Voltage Alternating Current		C10-765871-4AP4 (subassembly)	Amphenol	1	U phase output	U
				2	V phase output	V
				3	W phase output	W
				4	Motor ground	PE
				A	Temperature feedback positive	PT1000+

				B	Temperature feedback negative	PT1000-
Low voltage signal		RTOW01419PN03- SP20W1F- RTFD14B-	Amphenol	A	Control Power Positive	PWR+
				P	Control Power Negative	PWR-
				M	Control Power Shield	PWRS
				S	CAN Negative	CAN_L
				E	CAN Positive	CAN_H
				F	CAN Shield	CANS
				J	High-Voltage Interlock	HVLOCK
				K	High-Voltage Interlock	HVLOCK
				B	/	/
				C	/	/

				D	/	/
				G	/	/
				H	/	/
				L	/	/
				R	/	/
				T	/	/
				U	/	/
				N	/	/
				V	/	/

4. Design verification tests

Table 6 Verification tests

NO	DV test item	Parameter	Current status
1	Full Performance Map Test	Internal Standard	√ pass
2	Operating Point Performance Test	Internal Standard	√ pass
3	Cooling Runner Seal Test	Internal Standard	√ pass
4	Cooling runner resistance Test	Internal Standard	√ pass
5	Dynamic Response Test	Internal Standard	√ pass
6	Insulation Resistance Test	Internal Standard	√ pass
7	Vibration Performance	SAEJ 2380-2009	√ pass
8	Mechanical Shock	GB/T 31467.3-2015	√ pass
9	Waterproof and Dustproof	GB/T 4208-2017	√ pass
10	Low Temperature Performance	Internal Standard	√ pass

NO	DV test item	Parameter	Current status
11	High Temperature Performance	Internal Standard	√ pass
12	Temperature Shock Test	IEC 60068-2-14 Nb	√ pass
13	Salt Spray	GB/T 10125-2012	√ pass
14	Cyclic Damp Heat Test	IEC 60068-2-30-2005 IEC 60068-2-38-2009	√ pass
15	Acoustic Noise Test	GB/T 4980	√ pass
16	Withstanding Voltage	GB/T 18488. 2-2015	√ pass
17	EMC	GB/T 18655-2018	√ pass
18	Endurance Test	Internal Standard	√ pass
19	Passive Discharge	GB/T 18488. 2-2015	√ pass
20	Cleanliness	ISO 16232	√ pass
21	Prohibited Substances	GB/T 30512-2014	√ pass

5. Product Installation

Users will bear all mechanical and electrical responsibilities related to mobile products and installation of products.

After the package is disassembled, make sure that you do not drop it or receive any impact when moving the product to the installation site.

5.1 Product Fixation

First fix the 4 bolt holes on the legs of the air compressor to the bracket. The fixing bracket is provided by the customer, and the fixing bolt adopts M8 hexagonal flange bolts in accordance with Q184 standard. It is recommended that the processing surfaces of the 4 legs of the air compressor closely fit the mounting surface of the bracket. The air compressor should be installed horizontally (horizontal installation includes forward installation and hoisting). As shown in Figure 3. And the maximum allowable angle with the plane is $\pm 10^\circ$. When installing the air compressor, avoid collision with other products.

The default installation direction of the air compressor is horizontal installation, and the direction of the air compressor's exhaust port is horizontal. If you need other installation methods or adjust the direction of the exhaust port, you need to communicate with Segar Turbo technical staff in advance. Poor performance or damaged air compressor.

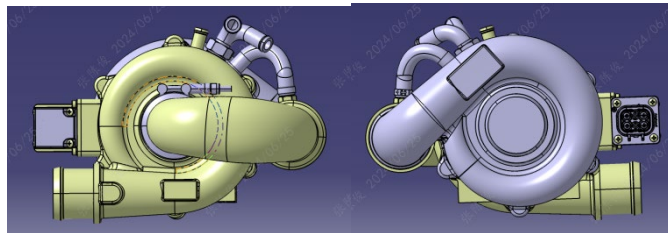

Figure 3 Air Compressor Installation Location Diagram

5.2 Coolant Line Connection

When the air compressor and the controller are connected to the coolant pipeline, ensure that the pipeline is completely sealed to avoid leakage. Ensure that the coolant flow direction is consistent with the inlet and outlet direction of the air compressor coolant.



The temperature of air compressor cooling water is 10~12 degrees higher than the intake air temperature/ambient temperature, to avoid the condensation of water vapor in the air on the outer surface of the air compressor cold water shell and the internal motor stator.

Please close the cold water system in time when the air compressor stops running, to avoid condensation of water vapor in the air on the external surface of the cold water shell of the air compressor and the internal motor stator.

5.3 Air compressor ground wire connection

Make sure the air compressor is properly grounded by connecting the grounding wire (prepared by customer) through the grounding screw (as shown in Figure 4). This will prevent the air compressor from short-circuit, making the motor shell electrified, causing injury to personnel and damage to the air compressor. And prevent the controller from failure or even damage due to short-circuit, making the air compressor work abnormally.

groundscrew

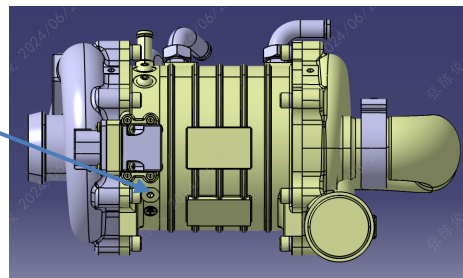

Figure4 Air compressor grounding screw diagram

5.4 Electrical Connections

Connect the AC wire harness to the joint socket.



Start the low-voltage control power supply after power-on, confirm the communication status and heartbeat function are normal, and then connect the high-voltage DC power supply. The power-on sequence cannot be changed.

5.5 Air Compressor Rotation Direction Confirmation

Confirm the steering of the first-stage impeller at the inlet of the air compressor: Separate the air inlet from the pipeline to ensure that the rotation of the impeller can be clearly seen. Start the air compressor at 100r / min, and see if the impeller steering is in the same direction as the volute (The airflow of the volute is from the small cross section to the large cross section of the volute) , as shown in Figure 5.



Make sure the air compressor is grounded before powering on.Start the low-voltage control power supply after power-on, confirm the communication status and heartbeat function are normal, and then connect the high-voltage DC power supply. The power-on sequence cannot be changed.

After confirming the steering, connect the air compressor inlet line. Ensure that the outlet of the air compressor is reliably connected to the system piping. It is strictly forbidden to loosen it and prohibit the human body from approaching the inlet and outlet of the high-speed air compressor.

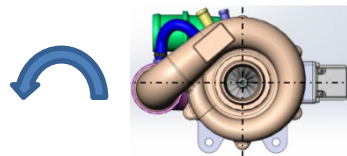

Figure5 Air Compressor Steering Confirmation Chart

5.6 Air Duct Connection

Ensure that the inlet and outlet of the air compressor are reliably connected to the air pipeline without leakage. There is additional high pressure at the air outlet, please ensure that the connecting pipeline is fully fixed (the outlet pipeline falling off during operation may cause damage to the air compressor). Assemble the pipeline after confirming that the rotation direction of the air compressor is correct.

The cooling air of the air compressor is introduced into the first-stage shell from the intermediate pipe through the hose, and finally discharged from the motor cavity. The cooling air connections are all sealed, and the hose is a silicone hose for vehicles. During installation, be careful not to bend or damage the hose.

The cooling gas exhaust cap should be removed. The cooling gas exhaust port should be connected with a hose. The exhaust port is recommended to be introduced into the atmosphere through the pipeline. Prevent rainwater from flowing into the cooling gas exhaust line. The pressure loss less than 3kPa.



Install an air filter on the intake duct to prevent foreign matter from entering.

Install the air inlet pipe after checking the rotation direction of the air compressor.

5.7 Checklist

Table11 Checklist

Project	Yes	No
Whether the air compressor is installed horizontally		
Whether the air compressor and the controller are firmly connected		
Whether the air induction hose of the air compressor has no obvious creases or cracks		
Whether the air compressor and controller are used to support other components		
Is a suitable filter installed in front of the air intake pipe		

Whether the inlet and outlet of the air compressor are firmly connected to the pipeline

Whether the coolant line is connected correctly

Whether the coolant leaks

Are the wire harnesses connected in place

Whether the air compressor and the controller are properly grounded

Whether the cooling gas exhaust port can prevent dust and rain from entering

6. Operation and Shutdown

6.1 Operation

Please keep the air compressor working in the speed range of 30000 ~ 95000r / min, otherwise it will cause the life of the internal bearing to be reduced or directly damaged.



After the high-voltage power supply is given, it may cause a danger of electric leakage. Do not touch the air compressor and the inverter.

6.2 Shutdown

After the shutdown operation, when the air compressor is completely stopped, first disconnect the high-voltage DC power supply, and then disconnect the low-voltage power supply.



Changing the power-off sequence may damage the internal components of the controller.



After the power is turned off, if you need to remove the wiring harness or mobile equipment, you need to wait for more than 120s to prevent the risk of electric shock caused by internal discharge of the controller.

When separating the air compressor and the connecting pipe, first make sure that all power supplies are disconnected, and the coolant system outlet valve is closed. Then check the coolant temperature, the surface temperature of the air compressor and the controller. After fully cooling, the connecting pipe and cooling pipe can be separated.

After the high-speed operation of the air compressor, the surface temperature of the air compressor and the controller rises, and direct contact may cause different degrees of burns.

6.3 Troubleshooting

Troubleshooting measures

Trouble	Measure
Sudden power failure	Free stopping of the air compressor without additional measures
Surge	Increase the exhaust valve opening

No feedback signal from air compressor

Check CAN signal and LV power supply

Controller feedback motor over temperature

Check whether the AC harness of the controller and the air compressor are connected well

Controller feedback overcurrent

Check whether the AC harness of the controller and the air compressor are connected well

7. Warnings & Cautions

Installation & Operation:

- During product handling, please do not hand carry the middle connection pipe, but use two hands to hold the bottom of the volute on both sides respectively.
- During product installation, please avoid physical shocks.
- Prevent all foreign objects that may cause damage to the product from entering the product.
- The coolant flows into the controller first and then into the air compressor, and the cooling line should be connected strictly in accordance with the input and output regulations, and is prohibited from being connected in reverse, as detailed in section 5.3.
- Make sure the installation is complete and secure when using the product.
- Make sure the air compressor is grounded before powering on. Before powering up, first start the low-voltage control power, confirm the

communication status and heartbeat function is normal, and then connect the high-voltage DC power.

- The air compressor cooling water temperature is 10~12°C above the inlet air temperature/ambient temperature to avoid water vapor in the air from condensing on the outer surface of the air compressor housing and the internal motor stator.
- When the air compressor stops operating, please turn off the cooling water system in time to avoid water vapor in the air from condensing on the outer surface of the air compressor housing and the internal motor stator.
- When installing, make sure that the outlet of the compressor is connected to the system piping reliably and is not allowed to be loosened. During operating, no pressure, sudden loss of pressure or blockage at the outlet of the compressor is strictly forbidden. Remember not to be near the inlet and outlet of the compressor operating at high speed.
- Do not start or operate the product when the exhaust valve is closed. When the exhaust valve is fully open, the air compressor can run at 30,000rpm (within 10min) for a short time. Then set the exhaust valve opening strictly according to the normal operating condition range of the air compressor performance curve in section 2.3.
- Please make sure that the conversion speed $\leq 95,000\text{r/min}$ during stable operation. Set the physical speed within 30,000r/min~95,000r/min.
- Conversion speed $n' = n \times (298/t_{in})^{0.5}$, “n” is the physical speed in rpm; “ t_{in} ” is the air compressor inlet temperature in K.
- When the air compressor speed is 0, the enable signal cannot be ON all the time, otherwise it will cause the air compressor temperature to rise too fast.
- Make sure the air compressor is completely stopped before disconnecting the high voltage power and low voltage power.
- Pay attention to safety when unplugging and plugging to avoid causing personal injury.

- Do not attempt to run the product again until you have ensured that the product is free from damage prone conditions.



Cautions

The product warranty will be voided if the user decides to modify the product, install or use the product incorrectly. In such cases, Xeca Turbo reserves the right to charge a fee for repair.

Generally:

- Do not modify the product without the manufacturer's permission.
- Read the documentation and safety warnings that come with the product carefully.
- Do not use the housing or components of the air compressor to support other products.
- Do not store the product in places with safety hazards.
- Do not use in combination with other products without the approval of Xeca Turbo.
- Do not change the parameters related to the operation of the product without the approval of Xeca Turbo.

8. After-sales Service

If you have any questions during the installation, operation and maintenance of the product, please use the following contact phone number and e-mail to seek the help of the technical staff of Xeca Turbo.

Tel: +86 0513-69921800

E-mail: support@xecaturbo.cn

